

PROPRIETARY AND CONFIDENTIAL

ITEM NO.	PART NUMBER	DESCRIPTION	QTY.	REVISION	MATERIAL
1	DRSQT38007-20	BOTTOM TRIM	1	A	SATIN/22
2	DRSQT38006-20	TOP TRIM	1	B	SATIN/22
3	DRSQT003-20	SIDE TRIM	2	B	SATIN/22

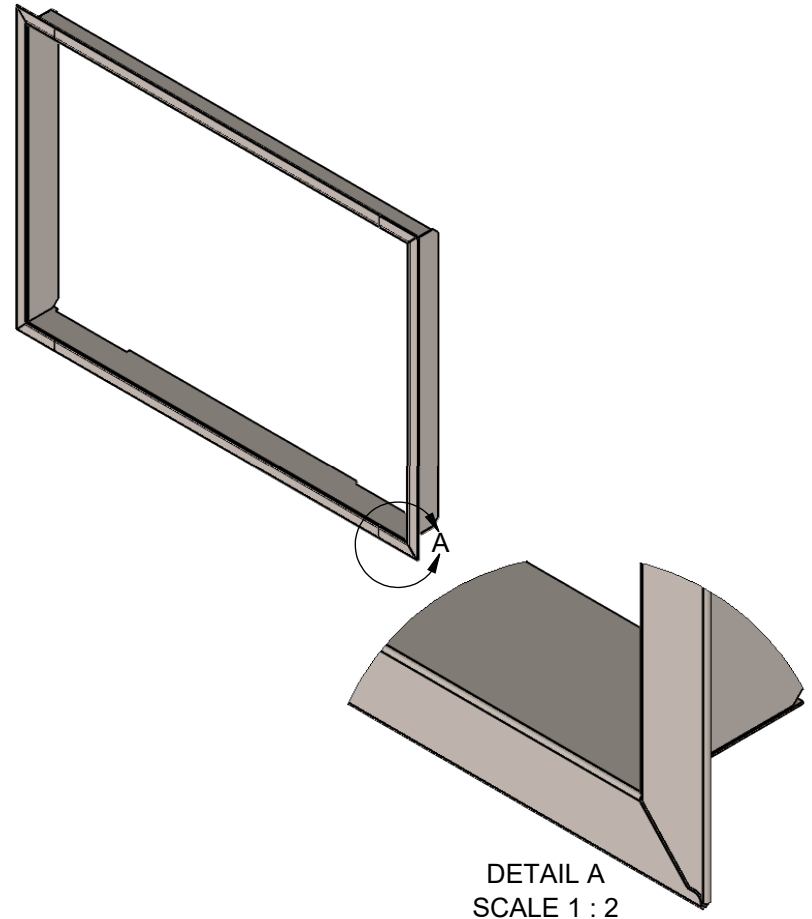

DETAIL A
SCALE 1 : 2

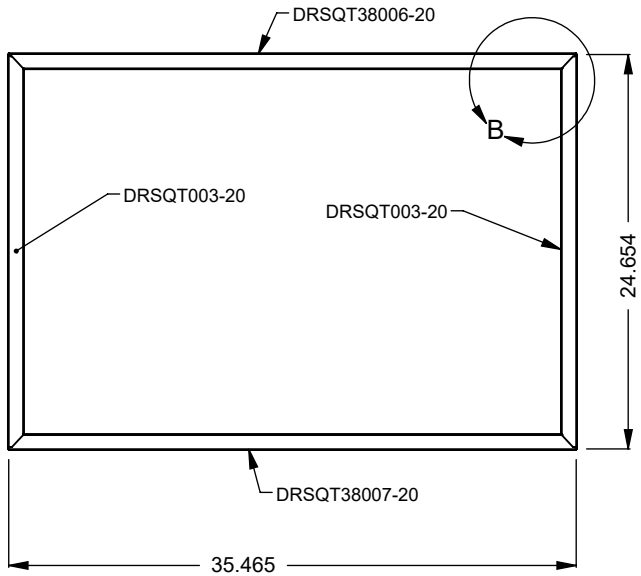
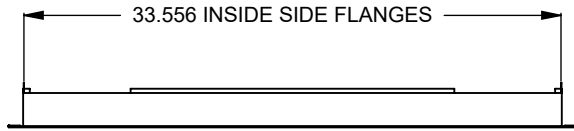
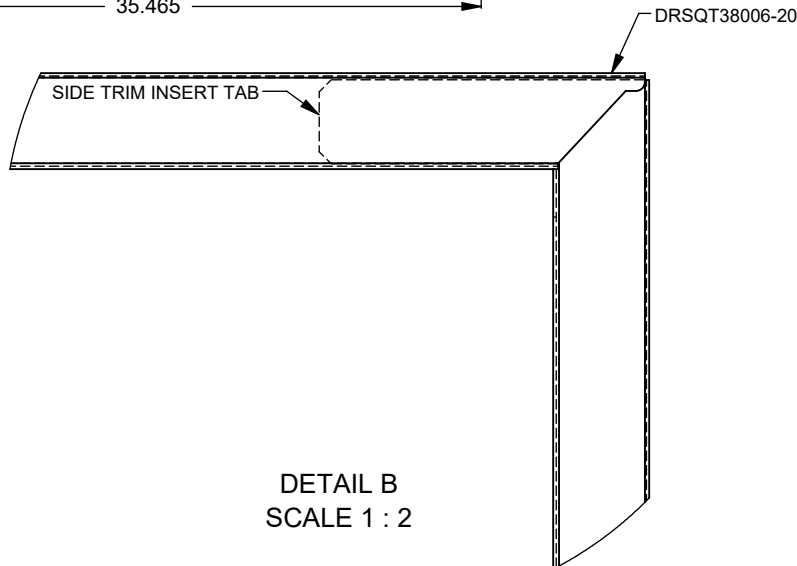

DETAIL B
SCALE 1 : 2

DRSQ38 1 1/2" - 2" in TRIM FRAME ASSY

DIMENSIONS ARE IN INCHES
TOLERANCES:
FRACTIONAL ± 1/32"
TWO PLACE DECIMAL ± .015"
THREE PLACE DECIMAL ± .005"
ALL BENDS ARE ASSUMED
TO BE 90° UNLESS NOTED
OTHERWISE.

	NAME	DATE
DRAWN BY	DB	3/25/2020
CHECKED BY		
MATERIAL	MTK	
K-FACTOR		

MONTIGO
the art of fireplaces

SIZE	DWG. NO.	REV.
A	DRSQ38 1.5-2in TRIM FRAME ASSY	A
SCALE 1:12	WEIGHT:	SHEET 1 OF 2

Y:\Products\Residential Products\R&D Projects\DeRay Square\DeRay Square\DRSQ38 1.5-2in CLEARANCE\DRSQ38 1.5-2in TRIM FRAME ASSY.FAS\$6, 2020 12:39:43 PM